

SEM816D Track Type Tractor



※ Featured machines in photos may include optional equipment

SEM816D

Efficient: The electronically controlled hydrostatic drive system and multi functional joystick provide high levels of performance and maneuverability.

Comfortable Operation: The cabin is ergonomically designed for increased operator comfort and visibility. The advanced monitoring system tracks machine operating conditions and keeps the operator informed of all vital machines functions.

Reliable: The proven hydrostat design along with world class pump and motors provide a highly reliable tractor. The undercarriage components are designed for longer life versus the leading competitor.

Serviceability: The SEM tractors are designed for easy access to reduce overall maintenance time. The machines electronic control module allows for quick troubleshooting.

Website <http://www.semmachinery.com>



A Caterpillar Brand

Main Specification

Model	SEM816D	SEM816D LGP	SEM816D DS	SEM816D CH	SEM816D FR		
Operating Weight	16,900kg	19,490kg	19,760kg	17,160kg	18,580kg		
Ground Pressure	66.8kPa	31.1kPa	34.8kPa	61.8kPa	66.9kPa		
Ground Clearance	410mm	410mm	410mm	410mm	410mm		
Max.Slope	30°	30°	30°	30°	30°		
Engine							
Model	WD10G178E25	WD10G178E25	WD10G178E25	WD10G178E25	WD10G178E25		
Rated Power	131kW	131kW	131kW	131kW	131kW		
Working Tool							
Blade Type	SU	S	LGP	LGP	U	SU Forestry	S Forestry
Blade Capacity	4.3m3	3.5m3	3.4m3	3.4m3	5.6m3	6m3	5.8m3
Blade Width	3,180mm	3,590mm	4,410mm	4,410mm	3,580mm	3,180mm	3,590mm
Blade height	1,240mm	1,165mm	1,000mm	1,000mm	1,400mm	1,625mm	1,625mm
Max. Blade Digging Depth	430mm	430mm	470mm	470mm	430mm	430mm	430mm
Max.Blade Lift Ground Clearance	1,041mm	1,041mm	1,055mm	1,055mm	1,041mm	1,041mm	1,041mm
Max.Output Rimpull	280kN		280kN	280kN	280kN	280kN	
Maximum Digging Depth Of Ripper	584mm	/	/	584mm	584mm	584mm	
Maximum Clearance Under Tip	615mm	/	/	615mm	615mm	615mm	
Powertrain							
Type	dual-path, closed loop electronically controlled hydrostatic drive system						
Travel Speed-F/R	infinitely variable speeds 0-10 km/h						
Steering & Brake	hydrostatic steering; wet,multi-disc brake						
Minimum Streeing Radius	3,610mm	3,740mm	3,740mm	3,610mm	3,610mm		
Undercarriage							
Track Shoe Width-Single	510mm	/	950mm	560mm	560mm		
Track Shoe Width-APEX	/	1,050mm	950mm	/	/		
Track Shoe Quantity	37	42	42	37	37		
Length Of Track On Ground	2,430mm	2,925mm	2,925mm	2,430mm	2,430mm		
Track Gauge	1,880mm	2,300mm	2,300mm	1,880mm	1,880mm		
Track Roller Quantity	6	7	7	6	6		
Carrier Roller Quantity	2	2	2	2	2		
Hydraulic System							
Type	center close, pilot control						
Implement Hydraulic System Pressure	19 MPa						
Service Refill Capacities							
Fuel Tank	320L	320L	320L	320L	320L		
Cooling System	45L	45L	45L	45L	45L		
Engine Crankcase	24L	24L	24L	24L	24L		
Final Drive (each side)	30L	40L	40L	30L	30L		
Hydraulic Tank	140L	140L	140L	140L	140L		
Pivot Shaft Case (each side)	1.2L	1.2L	1.2L	1.2L	1.2L		

Optional Accessories

S = Standard, O = Optional, - = N/A	SEM816D	SEM816D LGP	SEM816D DS	SEM816D CH	SEM816D FR
WDEC (China Stage II)	S	S	S	S	S
Sandblast	-	-	S	-	-
Higher Air Cleaner	-	-	S	O	-
SU Blade	S	-	-	-	-
S Blade STD	O	-	-	-	-
U Blade	O	-	-	S	-
S Blade LGP	-	S	S	-	-
S/SU Forestry Blade	-	-	-	-	S
Winch	-	-	-	-	O
Rear Ripper w/3 Teeth	O	-	-	O	O
SG Shoe (510mm)	S	-	-	-	-
SG Shoe (560mm)	-	-	-	S	S
SG Shoe (950mm)	-	-	S	-	-
APEX Shoe(1,050mm)	-	S	O	-	-
APEX Shoe(950mm)	-	O	O	-	-
Carrier roller	S	S	S	S	S
Track roller (one side 6 units)	S	-	-	S	S
Track roller (one side 7 units)	-	S	S	O	-
Hystat Powertrain	S	S	S	S	S
Super PVD	S	S	S	S	S
Radio	O	O	O	O	O
Product link	S	S	S	S	O
Diagnostic code display	O	O	O	O	O
55A Alternator	S	S	S	S	S
12V Transverter	O	O	O	O	O
LED	O	O	O	O	O
Beacon	O	O	O	O	S
STD Cab	S	S	S	S	S
Belt line Cab	O	-	-	O	-
Canopy	-	-	-	-	O
Rear Electric Heated Glass	S	S	S	S	S
HVAC	O	O	O	O	O
Rest Pedal	S	S	S	S	S
Tools Box	S	S	S	S	S
Cup Holder	S	S	S	S	S
Sunvisor Hook	S	S	S	S	S
Fuel Gauge	S	S	S	S	S
Door wiper	O	O	O	O	O
ROPS/FOPS	O	O	O	O	S
Sweep and Screen Guards	-	-	-	-	S
Rear Guards	-	-	-	-	S
Cold Start(inlet gas heat-10C --25C)	O	O	O	O	O
Cold Start(cooling water heat-25C --40C)	O	O	O	O	O

Caterpillar (Qingzhou) Ltd. Address: No.12999 Nanhuan Road,Caterpillar Industrial Park, Qingzhou City,Shandong Province, Zip Code: 262500 P.R.China

© Materials and specifications are subject to change without notice. Featured machines in photos may include optional equipment. See your SEM dealer for available options.

© 2017 Caterpillar (Qingzhou) Ltd. All Rights Reserved. SEM Machinery, SEM, their respective logos, trade dress as well as corporate and product identity used herein, are trademarks of Caterpillar (Qingzhou) Ltd. and may not be used without permission.

Version: November 2017

Dimensions

SEM816D

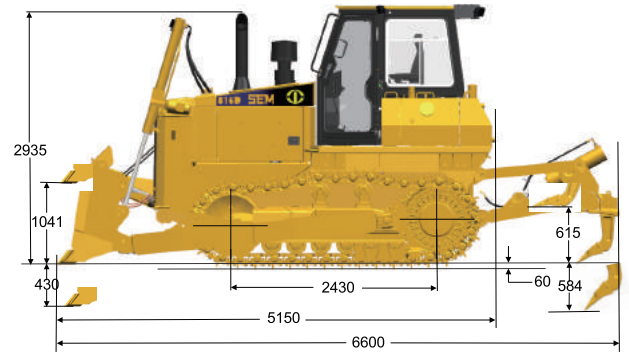
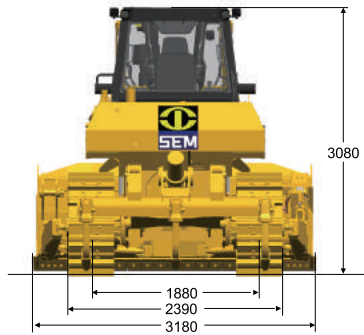

SEM816D LGP

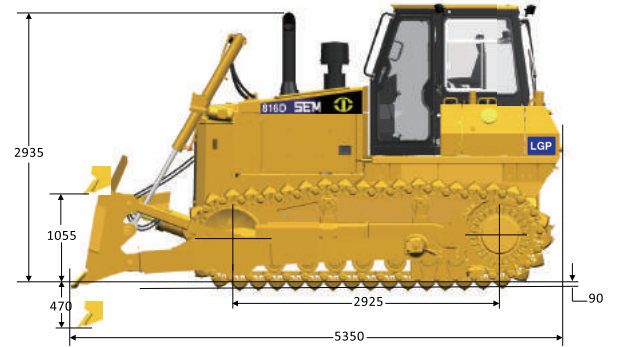
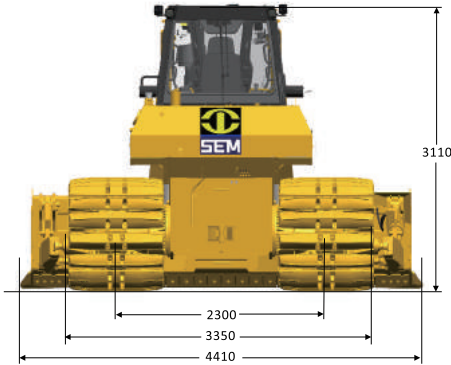

SEM816D CH

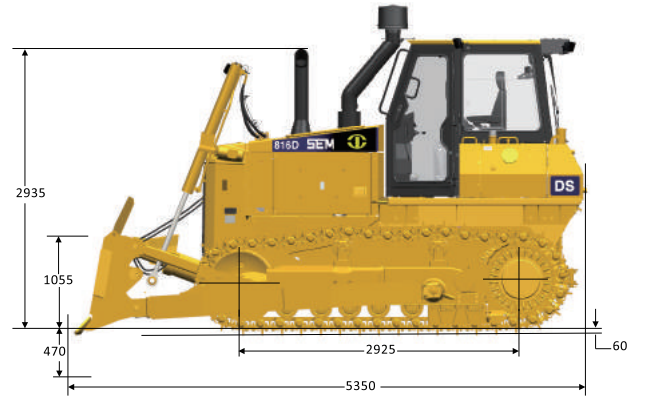
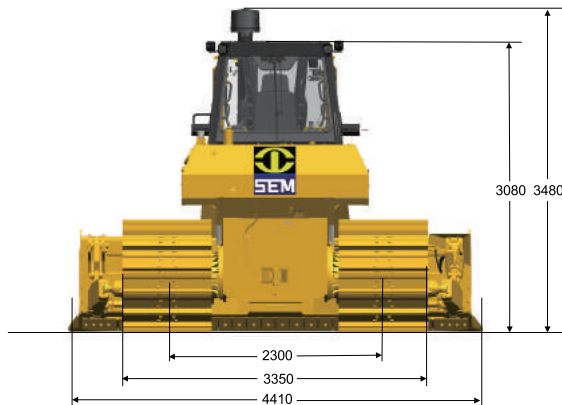

SEM816D DS

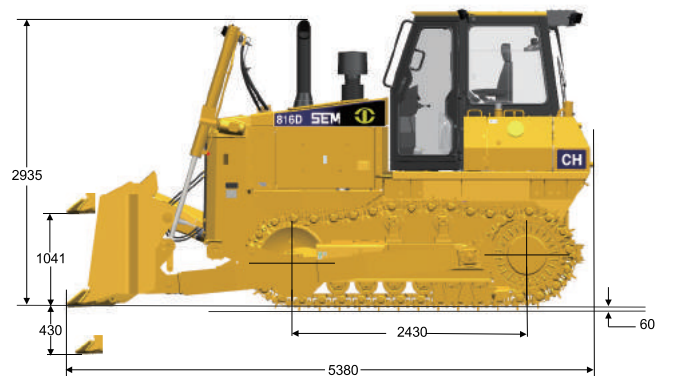

SEM816D FR

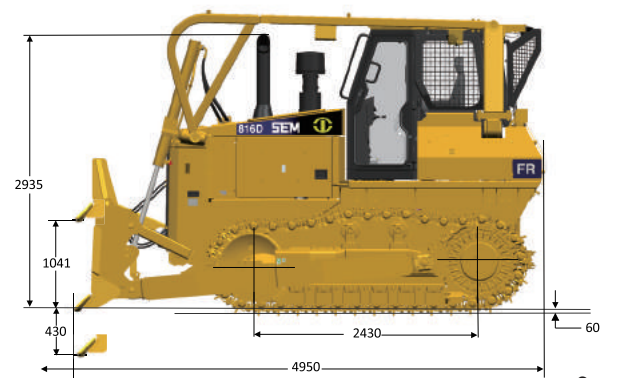
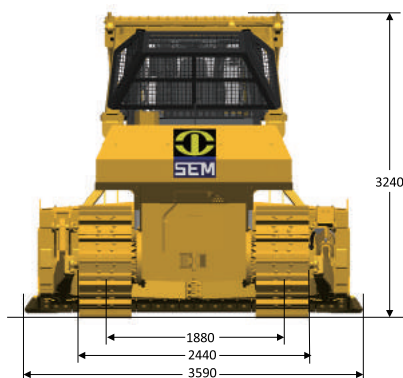

Modular Radiator

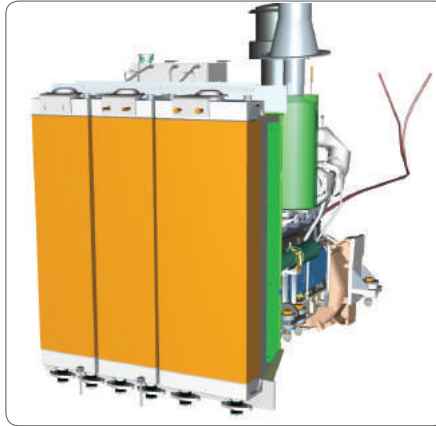
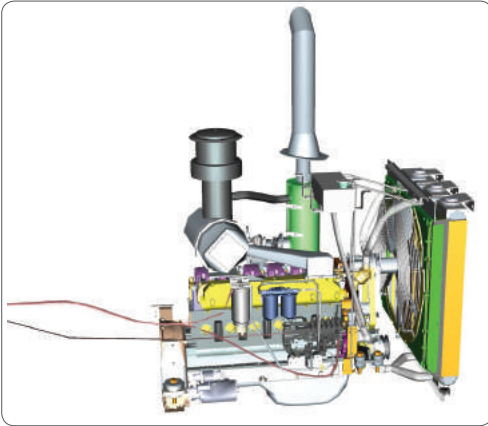

- New advanced cooling system designed to meet -40°C to $+50^{\circ}\text{C}$ ambient temperatures capability.
- Modular designed radiator, easy to maintain, remove and repair.
- Radiator grill provides better heat dissipation, easy access for maintenance.

Maintenance



- Electronic Control Module (ECM) fault diagnosis system, automatic diagnosis of eight key parameters.
- Monitoring system provides three levels of alarm, to indicate fault diagnosis.
- Hydrostatic system has longer service interval (2000 hrs), reduces maintenance time by 50%.
- Implement valve mounted outside of hydraulic tank provides easy access to check and service.

Blade Options



Semi-Universal blade
(with hydraulic tilt)



Straight blade

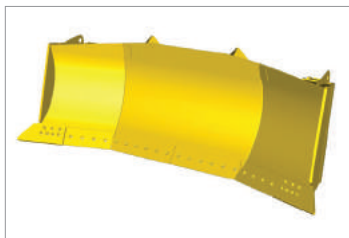

U Blade

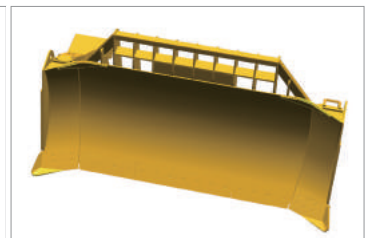

SU Forestry

Optional Attachments



ROPS/FOPS Cab



Multi-Shank Ripper(3 ripper shanks)



Air Conditioning



Cold Weather /
Arctic Oils

Semi-Universal Blade



Semi-Universal (SU) blade

- SU blade combines the excellent penetration of the S blade and the high production capacity of the U blade.
- Designed for superior load retention and penetration in tightly packed materials.
- L-shaped push arms bring the blade closer to the machine, providing excellent maneuverability, balance and blade penetration.
- Blades feature a strong box section design, made from high tensile strength steel to stand up to the most severe applications.

Undercarriage

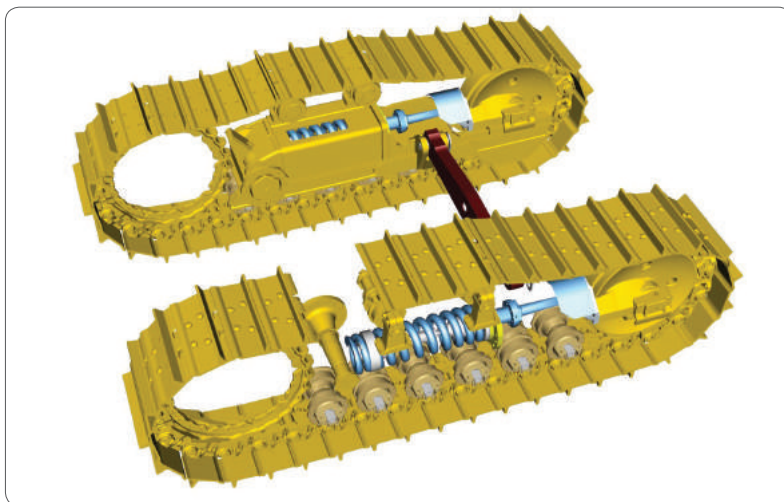

- Undercarriage is provided by China industry expert ensures high reliability and resistance to wear.
- Carrier rollers, track rollers and idle rollers are all maintenance free.
- Planetary final drive design delivers increased torque ratio for higher transmission efficiency and lower maintenance cost.
- Durable final drive bearings and multiple wet disc brakes provide reliability, reduce system heat and extend overall life.

Structures

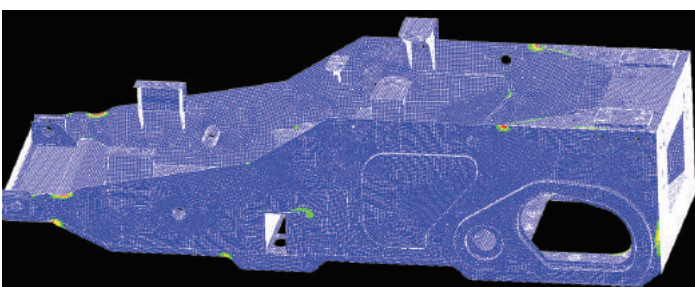

- Machine structures are analyzed using Finite Element Analysis (FEA) and On Machine Stress Analysis (OMSA) to identify and protect high stress areas.
- Advanced structure welding technique, relieving welding stress.

Cat® Product Link™ will support your business, and accurately convey information of the equipment to relevant personnel in a timely and effective manner for your better equipment management.



Hydrostatic Drive System



Upgraded hydrostatic system not only leverages Caterpillar automatic, dual path, hydrostatic drive with electronic control technology of the third generation TTT, but also increases efficiency and reliability.

- Adopt Rexroth German new generation one case drive pump to combine control valve, track motor, simplified hose line design, continue to increase the reliability.
- Caterpillar high pressure hose provides reliability and durability. Caterpillar control technology provides accurate control and high transmission efficiency.
- Integrated the hydrostatic oil tank and implement hydraulic oil tank to improve filtrated precision and cooling capability of hydraulic system, increasing reliability and reducing maintenance cost.
- Maintenance costs are reduced by 60% when compared competitors with torque converter and transmission and rear axle.
- Counter rotation, power turn and infinitely variable speed save lots of time, increasing working efficiency.

Comfortable Operation



Pilot joystick

- **Counter rotation**—Tracks counter rotate to provide best in class maneuverability.
- **Powered turn** —Machine maintains full power through turns to increase productivity.
- **Cruise control**—Operators can retain previous speed settings which makes operation easily.
- Multi-function joystick allows for counter-rotation, powered turn and cruise control.
- Pilot joystick control provides comfortable precise blade operation.